

HOW TO ORDER: **AUTOMATIC DOOR BOTTOMS** EXAMPLE - 7463CA-FX-36

**PART NUMBER & FINISH - OPTIONS - LENGTH (IN)**

**7463**

**CA**

**FX**

**36**

**PART NUMBER**

- 7063
- 7163
- 7263
- 7463
- 7563
- 7663
- 7963
- 7763
- 7863
- 7053
- 7153
- 7253
- 7553
- 71553
- 72553
- 7023
- 7323
- 7123
- 7033

**FINISH**

Please check each individual part for finishes available. Finishes vary based on the product.

- CA** - Clear Anodized
- DB** - Dark Bronze Anodized
- MA** - Mill Aluminum
- MB** - Matte Black Powder Coat
- WP** - White Powder Coat

**OPTIONS**

Please check each individual part for options available. Options vary based on the product.

- |                                 |   |                                   |
|---------------------------------|---|-----------------------------------|
| <b>Blank</b> - No Option        | <b>EMI</b> - Electromagnetic Interference | <b>LL</b> - Lead Lined            |
| <b>749</b> - Concealed Pull     | <b>EP</b> - Extended Plunger              | <b>PULL</b> - Pull Option         |
| <b>EA</b> - Electrical Actuator | <b>FL</b> - Fire Label                    | <b>PV</b> - Pivot Doors           |
| <b>EBB</b> - Draft Option       | <b>FX</b> - Integral Intumescent          | <b>SL</b> - Sliding Doors         |
| <b>EDP</b> - 1-1/2" Drop        | <b>LIG</b> - Ligature Resistant           | <b>TD</b> - Top Door Installation |

**LENGTH**

**AVAILABLE SIZES** - Can be made any size from 12" to 144".  
 Please specify to nearest 1/16"



HOW TO ORDER: **DOOR SWEEPS** EXAMPLE: 7823CA-LIG-36

**PART NUMBER & FINISH - OPTIONS - LENGTH**

7823

CA

LIG

36

PART #

- 7933
- 7736
- 7823
- 793
- 7836
- 7936
- 74918
- 71918
- 7774
- 73918
- 72918
- 718
- 799
- 7583
- 759
- 789
- 769
- 739
- 735
- 7183
- 71518
- 79418
- 7115
- 7283
- 7111
- 7011
- 7452
- 7552
- 7352
- 77918
- 711
- 78918
- 5241

FINISH

Please check each individual part for finishes available. Finishes vary based on the product.

- CA** - Clear Anodized Aluminum
- DB** - Dark Bronze Anodized Aluminum
- MA** - Mill Aluminum
- MB** - Matte Black Powder Coat
- WP** - White Powder Coat

LENGTH

Please specify to nearest 1/16"

OPTIONS

Please check each individual part for options available. Options vary based on the product.

- Blank** - Standard / No Option
- LIG** - Ligature Resistant
- ORB** - Oil-Rubbed Bronze
- EBB** - Draft Option
- PSA** - Pressure Sensitive Adhesive
- POL** - Polished Bronze
- FL** - Fire Label



#7823CA



#7183MA



#7452DB



#799MA

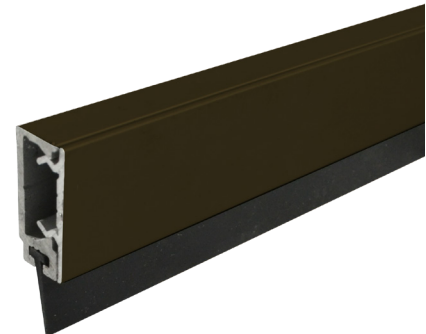

#7774DB

**HOW TO ORDER: SELF-ADHESIVE GASKETING** EXAMPLE: 5881S-BK-PSA-17FT

**PART NUMBER - COLOR - OPTIONS - LENGTH (FT)**

**5881S - BK - PSA - 17 FT**

**PART NUMBER**

5658S	5628SPR
5848S	50778SPR
5348SPR	50878SPR
5258SPR	5813SPR
1S	5018SPR
2S	5118SPR
3S	5218SPR
4S	413PB
5S	423PB
6S	443PB
7S	42PB
5088S	5911BR
5188S	53508
52718SPR	

**MATERIAL & COLOR**

Please check each individual part for options available. Options vary based on the product.

- BK** - Black
- BW** - Brown
- CL** - Clear
- WH** - White
- BF** - Brown Foam
- WF** - White Foam
- SPR** - Black Sponge Rubber
- GY** - Gray
- BR** - Spring Bronze

**OPTIONS**

Please check each individual part for options available. Options vary based on the product.

- Blank** - Standard / No Option
- LIG** - Ligature Resistant
- PSA** - Pressure Sensitive Adhesive

**LENGTH**

Please specify to nearest 12"



#50878SPR



#5881S-BK

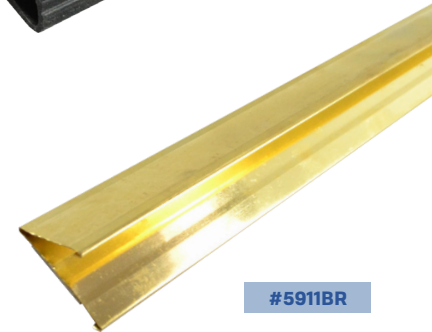

#5911BR



#52408S-BK



HOW TO ORDER: **GASKETING** EXAMPLE: 5077CA-FX-36

**PART NUMBER & FINISH - OPTIONS - LENGTH**

5077

CA

FX

36

**PART #**

- 5077SPB
- 5823SPB
- 5574SPB
- 5077
- 5071
- 5924
- 513
- 523
- 5078
- 5178
- 5075
- 5175
- 5823
- 5413
- 5203
- 53038
- 51888
- 52888
- 5584
- 5583
- 5574
- 5974
- 5874
- 5873
- 599
- 589
- 5027
- 5272
- 5041

**FINISH / MATERIAL**

Please check each individual part for finishes available. Finishes vary based on the product.

- CA** - Clear Anodized Aluminum
- DB** - Dark Bronze Anodized Aluminum
- MA** - Mill Aluminum
- MB** - Matte Black Powder Coat
- WP** - White Powder Coat
- SP** - Gray Steel Prime
- SS** - Stainless Steel

**OPTIONS**

Please check each individual part for options available. Options vary based on the product.

- Blank** - Standard / No Option
- PSA** - Pressure Sensitive Adhesive
- FL** - Fire Label
- LIG** - Ligature Resistant
- FX** - Fire Intumescent

**LENGTH**

Please specify to nearest 1/16"



#5071CA



#513CA



#5874CA

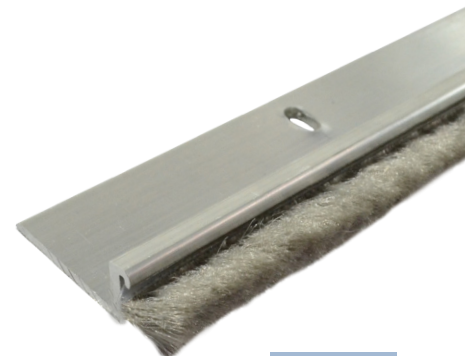

#589MA

HOW TO ORDER: **MEETING STILES / ASTRAGALS** EXAMPLE: 7383CA-84-TX

**PART NUMBER & FINISH - OPTIONS - LENGTH - FASTENERS**

**7383**      **CA**      -      -      **84**      -      **TX**

**PART #**

<b>BOTH DOORS ACTIVE*</b>	<b>ONE ACTIVE DOOR</b>
72918	714
74918	70481
73918	7383
7823	7041
7583	734
799	7933
789	774
7574	744
7974	
7075	
7175	
7078	
7178	
743	
763	
735	
795-FX	
77128S	
7893	
7731	
7831	

**\*NOTE**  
 Order quantity must be (2 each) for each leaf of the opening.

**FINISH**

Please check each individual part for finishes available. Finishes vary based on the product.

- CA** - Clear Anodized Aluminum
- DB** - Dark Bronze Anodized Aluminum
- MA** - Mill Aluminum
- MB** - Matte Black Powder Coat
- WP** - White Powder Coat
- SP** - Steel Prime

**LENGTH**

Please specify to nearest 1/16"

**OPTIONS**

Please check each individual part for options available. Options vary based on the product.

- Blank** - Standard / No Option
- LIG** - Ligature Resistant
- LL** - Lead Lined
- NH** - No Holes
- PSA** - Pressure Sensitive Adhesive
- FL** - Fire Label

**FASTENERS**

Please check each individual part for options available. Options vary based on the product.

- Blank** - Standard Fasteners supplied
- TX** - Security Fasteners



PAIR OF #7731



PAIR OF #74918CA



#735MA



#7383CA

HOW TO ORDER: **CONTINUOUS HINGES** EXAMPLE: 1019CA-HD-72

**PART NUMBER & FINISH** - **OPTIONS** - **LENGTH**  
1019 - CA - HD - 72

**FINISH**  
Please check each individual part for finishes available. Finishes vary based on the product.  
**CA** - Clear Anodized Aluminum  
**DB** - Dark Bronze Anodized Aluminum

**OPTIONS**  
**Blank** - Standard / No Option    **HD** - Heavy Duty    **AET** - Accessible Electric Transfer  
**LPT** - Legacy Power Transfer: The Legacy Power Transfer hinge is 8-1/2" long and mounted on the top of the door/frame.  
**LCS** - Legacy Concealed Switch: An SPDT switch is mounted on n elf the leafs.  
**LHT** - Hospital Tip: Primarily for security areas in Hospital, Prisons and Mental Health Facilities, Clean Rooms, Hospital tip hinge serves to assist in preventing hanging any objects on the tip of the hinge. This is a ligature resistant feature.  
**LST** - School Tip: Top of the hinge has a non removable top to prevent contamination  
**LSF** - Security fasteners: Tamperproof, Torx, Stainless Steel screws

**LENGTH** Please specify to nearest 1/16"

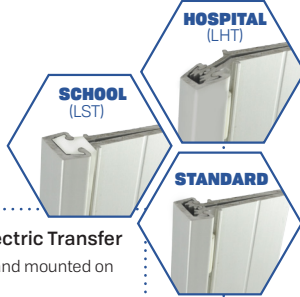

Continuous hinges distribute the weight of the door along the entire length of its frame by reducing the high stress normally associated with butt hinge applications. It also keeps the door in constant alignment, eliminating the chance of door sag. These characteristics make continuous hinges suitable for high-use, high-traffic doors, and acoustical applications.

Continuous hinges utilize a gear system held in place by a full-length cover channel and rotate on a series of bearings. The design of a continuous hinge eliminates the spacing between the hinges, which helps prevents fingers from being pinched, making it a safer device than traditional hinges.

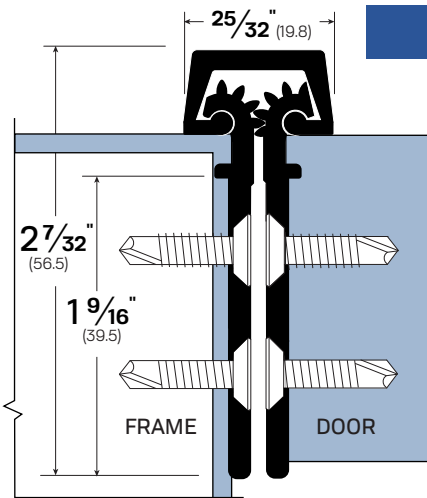

**#1019**

**FULL MORTISED CONTINUOUS HINGE**

**AVAILABLE FINISHES**

**CA, DB**

**OPTIONS**

- HD** - Heavy Duty
- LPT** - Legacy Power Transfer
- AET** - Accessible Electrical Transfer
- LCS** - Legacy Concealed Switch
- LHT** - Hospital Tip
- LST** - School Tip
- LSF** - Security fasteners

**NOTES**

- Standard option: 16-Bearings, Gray in color
- Custom lengths available upon request
- Door/ frame reinforcements are not required in most applications

LEGACY
1019
NGP
HD1100
PEMKO
FMSLE-HD1
ZERO
-

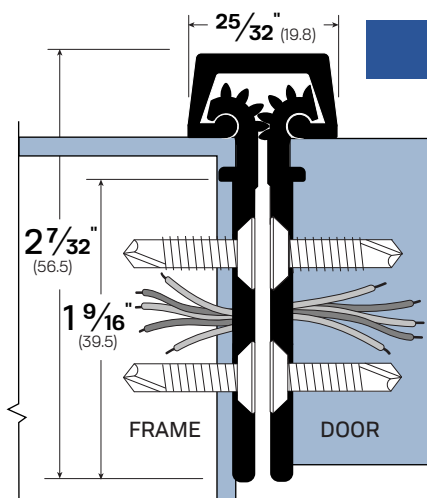

**#1027**

**ELECTRIFIED HINGE**

This hinge maintains a fluid door swing while, at the same time, evenly spreads stress along the full height of the door. The 1027 is removable without the need to re-hang the door.

**AVAILABLE FINISHES**

**CA** - Clear Anodized Aluminum  
**DB** - Dark Bronze Anodized Aluminum

**NOTES**

- Power Transfer Technology
- 26-gauge
- 6 wire standard, 12 wire optional
- Tamper-resistant
- Weather-resistant

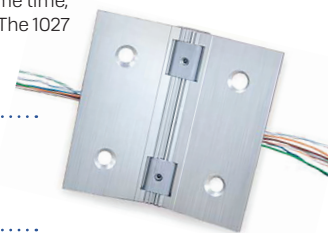

**#1027CA**

LEGACY
1027
NGP
-
PEMKO
-
ZERO
-

HOW TO ORDER: **THRESHOLDS** EXAMPLE: 30756BR-EPX-36-FA24

**PART NUMBER & FINISH - OPTIONS - LENGTH - FASTENERS**

**30756**

**BR**

**EPX**

**36**

**FA24**

**PART #**

3276	3912	395
3376	3012	3941
3476	3332	3325
3576	3432	3221SRE
3676	3632	3201
3776	35861SRE	3616
3876	36861SRE	3143
3976	3952	3144
30176	3852	3145
386	3445	3486
3862	3545	342
3962	3645	352
3964	3745	3514
3601	3845	30756
348SRE	3456	3501
346	3461	3148
1834	3556	3971
319	3656	3571
1412	3756	3006EJ
3465	3441	3106EJ
356	3541	3960
3665	3641	3966
3565	3741	3461
3291	3841	3561
3425	34761	3661
3512	35761	3761
3612	3061	
3712	3341	
3812	3942	

**FINISH**

Please check each individual part for finishes available. Finishes vary based on the product.

- BR** - Architectural Bronze
- DP** - Diamond Plate
- MA** - Mill Aluminum
- MB** - Matte Black Powder Coat
- SS** - Stainless Steel
- ST** - Steel

**LENGTH**

Please specify to nearest 1/16"

**OPTIONS**

Please check each individual part for options available. Options vary based on the product.

- ACF** - Aluminum Composite Filler
- EPX** - Epoxy Abrasive
- LS** - Lead Shields
- ORB** - Oil-Rubbed
- POL** - Polished
- RB** - Rubber Grip
- PEA** - Photoluminescent Epoxy Abrasive
- Specify **Stop Strip**
- Specify **Type #** Floor Closer

**FASTENERS**

FA21 - FA22 - FA 23 - FA24 - FA26

#3376MA-RUB

#3465MA

#30756BR

#3966DPSS

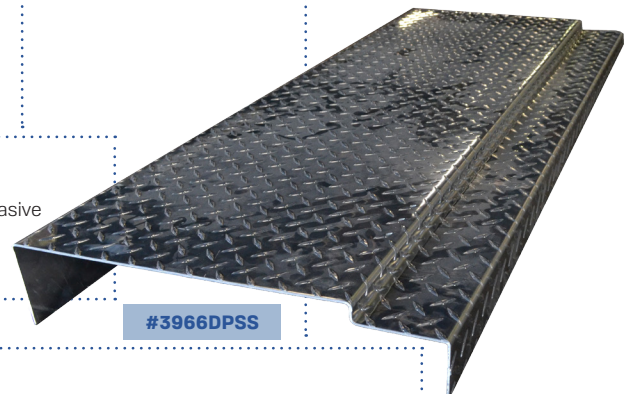
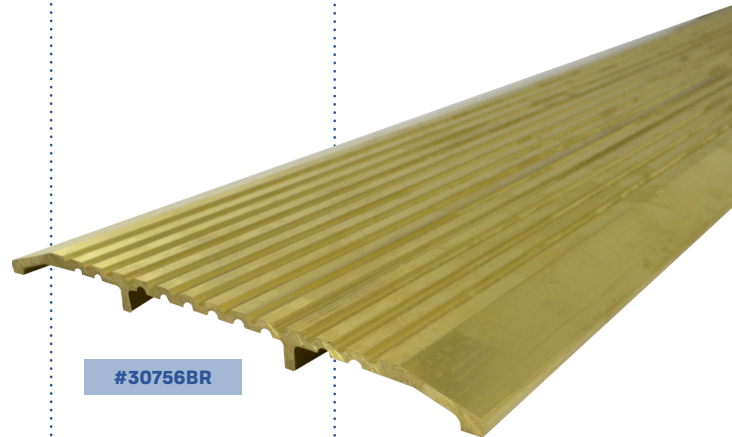
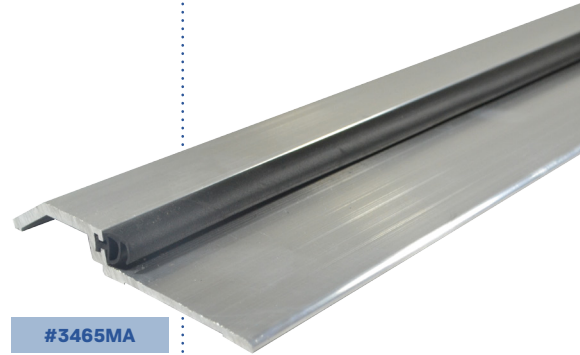
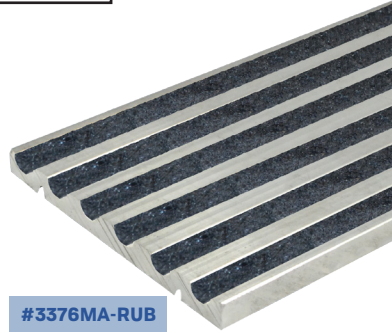

# Intumescent Strips (FX)

## CUSTOMIZABLE AND SPECIFIABLE

### MATERIALS / SPECIFICATIONS

- Custom length, widths, and thicknesses are available
- Used in fire/acoustical applications
- Environmentally safe, minimal carbon footprint
- Standard color is black. Red available. Specify RD
- Optional - Laminated to wood, aluminum, steel, or other solid materials

CUSTOM  
 MADE TO  
 ORDER ANY  
 SIZE AND  
 COLOR

LEGACY	13212	13219	13225	13244	13312	13319	13325	24625	24650
ZERO	3062500	3062750	30621000	30621750	312500	3125750	31251000	32501000	-

### INTU-FX TYPE #3 (30X EXPANSION)

#### #13212

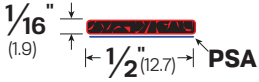

#### #13219



#### #13225

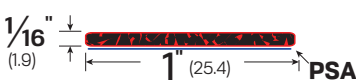

#### #13244



#### #13312

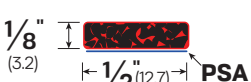

#### #13319



#### #13325



### INTU-FX TYPE #4 (120X EXPANSION)

#### #14212

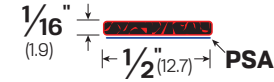

#### #14219

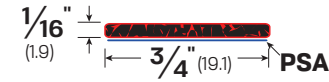

#### #14225

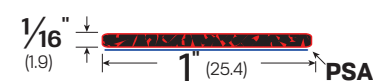

#### #14244

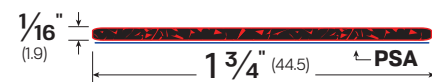

#### #14312

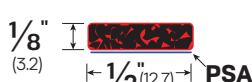

#### #14319



#### #14325



#### #24625



#### #24650

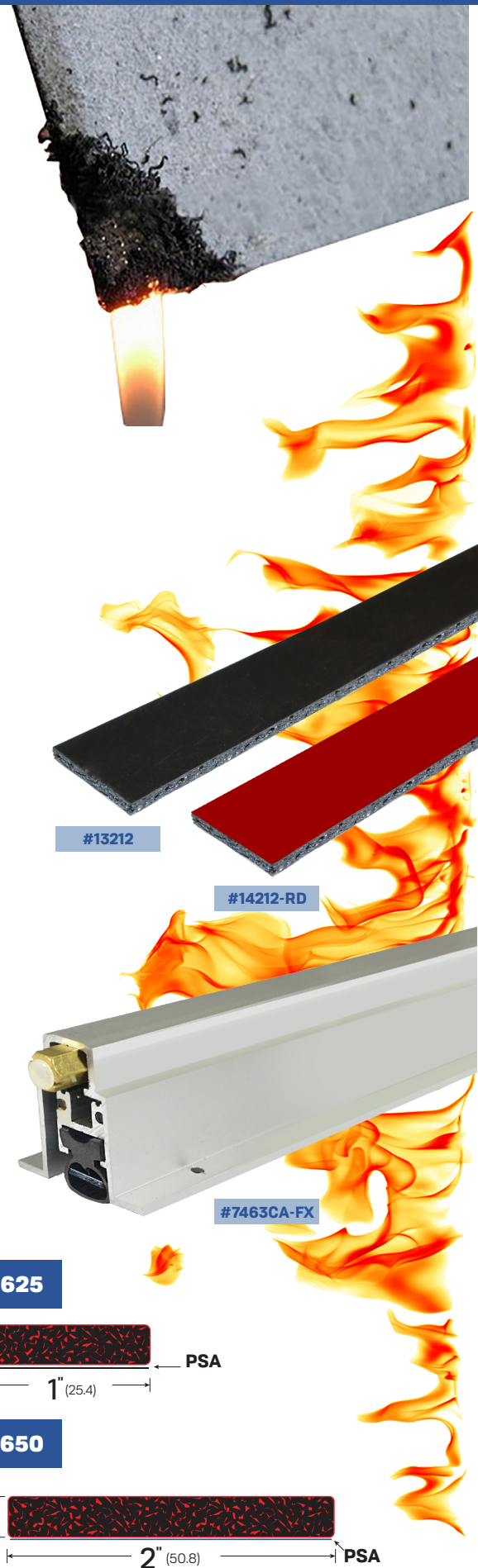



# Acoustical Soundproofing Insulation (ACS)

The Acoustical Soundproofing Insulation (ACS) material is a product of advanced design made in a sheet form, with a combination of sound absorbing and sound deadening characteristics for improved STC ratings.

The natural fiber used in this product is found in volcanic rocks and is known as a "21st-century nonpolluting green material". It is 100% natural and inert with no toxic reactions to air or water. ACS is non-combustible, non-explosive, non-carcinogenic, and non-toxic. In addition, this product is biodegradable with a low carbon footprint. A high melting point and low smoke index make this product safe to use in almost any location where fire codes are a concern. It is commonly used in CLMD (constrained layer mass damping) applications. This material is washable when used in exposed areas, such as restaurants, public spaces, temporary applications, hanging baffles, etc. It is mold-resistant, mildew-resistant, and flame resistant.



## MATERIALS / SPECIFICATIONS

- Solid pigmented, highly filled polyurethane rubber noise barrier



	#ACS250X_ - 1/4"	#ACS125X_ - 1/8"
--	---------------------	---------------------

STC Rating	28	24
Deficiencies	23	32
OITC Rating	24	19

## SOUND TRANSMISSION COEFFICIENTS

Frequency	STC - 1/4"	STC - 1/8"
125 Hz	18 db	14 db
250 Hz	20 db	15 db
500 Hz	25 db	20 db
1000 Hz	28 db	23 db
2000 Hz	32 db	37 db
4000 Hz	37 db	33 db
Sound Transmission Class:	28	24

Physical Properties	#ACS250X_ - 1/4" Sheet	#ACS125X_ - 1/8" Sheet
<b>Tensile Strength:</b> (Per ASTM D412-64)	375 lb./sq. in.	105.32 lb./sq. in.
<b>Elongation:</b> (Per ASTM D412-64)	113.2%	160%
<b>Tear Strength:</b> (Per ASTM D1004-66)	6.09 lb./in.	6.09 lb./in.
<b>Weight/ft. ²:</b>	1.337 lb./sq. ft.	0.7106 lb./sq. ft.
<b>Thickness:</b>	Approximately 0.250"	Approximately 0.125"
<b>Cold Crack:</b> (32°F)	No crack when bent over 1" mandrel	No crack when bent over 1" mandrel
<b>Flammability:</b>	Passes MVSS #302 UL94-SE "0"	Passes MVSS #302 UL94-SE "0"
	Classified as SE (Self Extinguishing)	Classified as SE (Self Extinguishing)
	No burn rate	No burn rate
<b>Recommended Service Temperature:</b>	40°F - 140°F	40°F - 140°F
<b>Notes:</b>	May be doubled for improved isolation	May be doubled for improved isolation
	Is resistant to oil, grease, & solvent	Is resistant to oil, grease, & solvent

The result reported above apply only to the test sample. No responsibility is assumed for performance of any other specimen.

HOW TO ORDER: **DOOR FLOOD BARRIERS**

**PART NUMBER & FINISH - HEIGHT - LENGTH - OPTIONS**

5027

MA

30

60

2275

**PART #**

- 5027
- 5099
- 5127
- 5125
- 5128
- 5029
- 5129

**FINISH**

Please check each individual part for options available. Options vary based on the product.

- MA** - Mill Aluminum
- 5052 marine aluminum alloy



#5027MA10-36

**HEIGHT**

Please specify to nearest 1"

**LENGTH**

Please specify to nearest 1/16"

**OPTIONS**

Please check each individual part for options available. Options vary based on the product.

- INSIDE** - Mounted to the inside of the frame
- OUTSIDE** - Mounted to the outside of the frame
- 2275** - Interlocking post for oversized units

- LCK** - Locking function
- SWBD** - Stackable Wave Barrier for higher vertical protection

**SWBD** - Stackable Wave Barrier

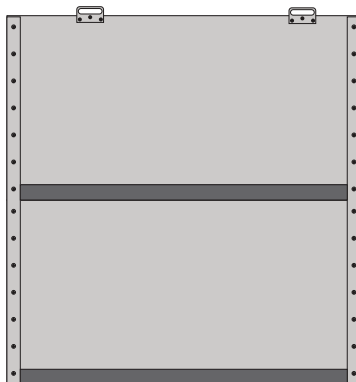

**INSIDE OR OUTSIDE** Mounting Location

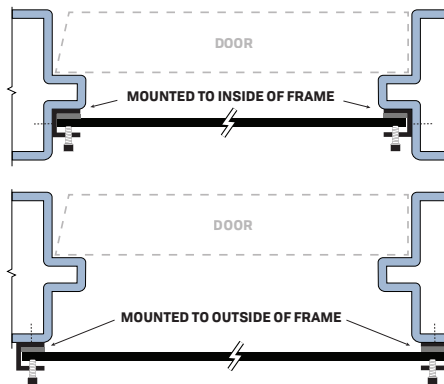

**2275** - Interlocking Post

